

EMS

20VA – 55VA Micro Inverter

The EMS Series is designed to provide 20 to 55 watts of emergency power to incandescent, fluorescent, and/or LED fixtures. The EMS unit provides clean, sinusoidal AC output power allowing it to be remotely mounted up to 1,000 feet away from the controlled fixture(s).

Unlike a ballast fluorescent emergency pack, the EMS provides power to the input side of the fixture, (including the ballast) eliminating any chance of incompatibility.



FEATURES

- For powering incandescent, fluorescent, and LED fixtures
- True sinusoidal AC pulse width modulated (PWM) design provides clean 60 Hz. emergency output
- Universal 120/277 VAC, 60Hz. input/output
- Unit capacities from 20 to 55 Watts
- “Soft Start” design reduces fixture inrush current
- Surface, recessed or T-Grid mount models
- Lumen output from fixture is 100% of nominal
- Unique design eliminates compatibility problems with LED drivers as well as fluorescent ballasts
- Normally-ON, Normally-OFF or switched outputs
- Temperature compensated, dual-mode charger includes low voltage disconnect feature to provide protection against battery deep discharge
- Maintenance-free Lead-Calcium and premium grade Nickel-Cadmium battery models offered
- Control panel with momentary test switch, AC-ON, Charge-ON and Inverter-ON LED indicators
- Battery circuit fuse protected
- Reverse battery and AC lockout protection
- Knockouts in back
- White powder coat finish

HOUSING

- Heavy duty steel cabinet has a white powder coat finish providing scratch and corrosion resistance.

INPUT

- Voltage: 120 or 277VAC \pm 10%
- Frequency: 120 or 277VAC \pm 10%
- Protection: Provided by Service Panel, Rated 20A max.

OUTPUT

- Voltage: 120 or 277VAC (60Hz)
- Efficiency Rating: 98% at full rate load (line)
- Waveform: Sinusoidal (digitally controlled, PWM design)
- Static Voltage: \pm 5% during battery discharge. 0-100% linear load
- Output Frequencies: 60 Hz \pm 0.3Hz during emergency cycle
- Output Distortion: Less than 3% THD (linear load)
- Transfer Time: Less than 1.0 second
- Load Power Factor Range: 0.44 Lead to 0.44 Lag
- Minimum Loading: 0% of rated system capacity
- Output Protection: Inverter fuse
- Power Consumption (max): 9W

MOUNTING

- Surface Mount: Surface mount models are designed for mounting to walls by means of keyhole slots provided in the back of the unit housing.
- Recess Mount: Recess models provide recess mounting holes on both sides of the enclosure.
- T-Grid Mount: Housing design allows simple drop-in installation between t-grid runs. Safety wires (supplied by others) are required for attachment to building structure.

WARRANTY / LISTING

- Unit: 3 years full coverage against defects in materials and workmanship from date of shipment.
- Battery: 3 years (Lead-Acid – 5 years NiCd) full warranty plus an additional 7 years of pro-rata coverage.
- View complete warranty terms online at www.evenlite.com/terms-warranty.
- All models are UL924 Listed and meet NFPA 101 Life Safety Code, NEC, OSHA, Local and State Codes. Optional T-Grid models are plenum rated.

ORDERING GUIDE

EMS-55-LC-V3-S

MODEL	VA RATING	BATTERY TYPE	INPUT/OUTPUT	OPTIONS	ORDERING NOTES
EMS	32 32 Watts/VA	LC Lead Calcium ¹	V3 120/277	S Surface Mount	1 Only available with [32] or [55] VA Rating options 2 Only available with [20] or [35] VA Rating options
	55 55 Watts/VA			RE Recessed Mount	
	20 20 Watts/VA	NC Nickel Cadium ²		TB T-Grid Mount	
	35 35 Watts/VA			RT Remote Test Switch	
EMS			V3	SD Self-Diagnostics CEC Certified to CEC under Title 20 Regulations	

Fill in fields from categories above and complete type and part number.

Type No: _____ Full Part No: _____

SYSTEM SPECIFICATIONS

MODEL	SYSTEM WEIGHT* (lbs)	BATTERY TYPE	TEMP RANGE (°C)	DC INPUT CURRENT (VDC)	INPUT CURRENT		THERMAL OUTPUT IN BTUS	
					120VAC	277VAC	STANDBY	EMERGENCY
EMS-32	14.0	Lead-Calc	20-30°	3.4	0.34A	0.15A	7	32
EMS-55	18.0	Lead-Calc	20-30°	5.7	0.54A	0.23A	7	47
EMS-20	11.0	NiCad	0-50°	2.1	0.25A	0.11A	31	22
EMS-35	12.0	NiCad	0-50°	3.8	0.37A	0.16A	31	35

*System weight shown included installed batteries

ADDITIONAL IMAGES



SURFACE MOUNT

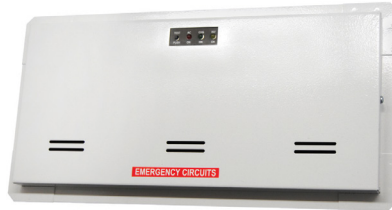

WALL RECESSED



T-GRID MOUNT

BATTERY

- Battery: Sealed Lead Calcium (10 year life) or Sealed Nickel-Cadmium (15 year life)
- Battery Voltage: 12VDC for all EMS models
- Runtime: 90 minutes standard. Other runtimes available, consult factory.
- Battery: Low Voltage Battery Disconnect protects the battery from being severely damaged by deep discharge during prolonged power failures.
- DC Overload and Short Circuit Protection provided by a DC input fuse. Battery voltage (VDC) 12

CHARGER

- Charger Type: Fully automatic, temperature compensated, dual-mode charger
- Power Consumption: 9W max (All models)
- Recharge Duty Cycle: Meets UL924 requirements
- Controls: Momentary test switch, AC-On, Charge-On and inverter-On LED indicator lights
- Safety Circuitry: AC lockout prevents battery discharge prior to initial unit power-up.
- Brownout Protection automatically switches the unit to emergency mode when utility voltage is significantly reduced.
- Environmental
- Altitude: < 10,000 feet (3,000m) above sea level without derating.
- Operating Temperature Range for Lead-Calcium Models: 68°F to 86°F (20°C to 30°C)
- Nickel-Cadmium Models: 32°F to 122°F (0°C to 50°C)
- Relative Humidity: 95% non-condensing
- NOTE: Optimum system performance between 20°C (68°F) and 30°C (86°F); temperatures outside of the range will affect battery performance and life.

OPERATION

- Upon failure of the normal utility power the EMS unit is automatically turned on by a solid state switching circuit and provides a minimum of 90 minutes of emergency power to the connected load. Lumen output will be maintained at 100% of the lamp's rating throughout the entire duration.
- A solid state low voltage disconnect circuit is used to protect the battery from being severely damaged by a deep discharge. When normal utility power is restored, the unit switches the load back to normal utility operation and the fully automatic, temperature compensated, dual mode charger begins to restore the battery bringing it to full charge within UL 924 specified parameters. A brownout sensing circuit insures proper operation during "low line" conditions.

IMPROVED AESTHETICS

- The EMS system's sinusoidal AC output design eliminates voltage drop and proximity concerns. This allows added flexibility in installation location as EMS units can be installed hundreds of feet from the units they power. This means EMS units to be located conveniently out of sight in closets or utility rooms without interrupting architectural aesthetics.

EMS SYSTEM ADVANTAGES

- Compared to traditional discrete emergency lighting units, the EMS Series provides emergency illumination from a single power source resulting in lower maintenance overhead and routine testing expenses. EMS units lower installation costs by powering existing lighting fixtures during emergencies. And because connected fixtures are driven at full brilliancy, they provide far superior egress lighting and deliver improved occupant safety.

DIMENSIONS

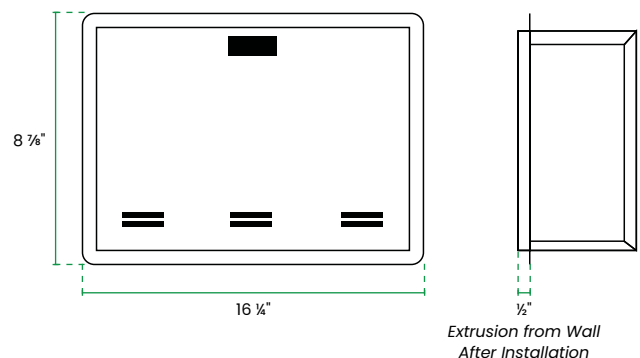
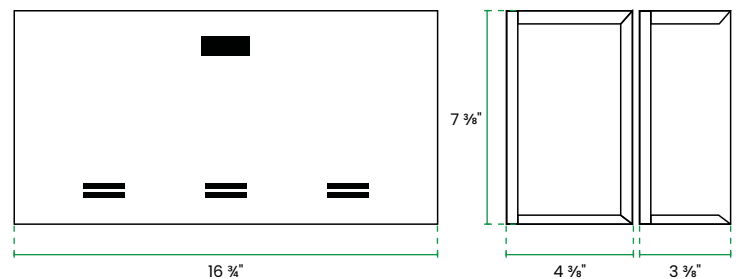

OPTIONAL CEILING T-GRID MOUNT HOUSING

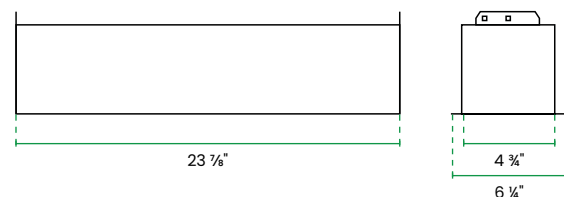

SUGGESTED SPECIFICATIONS

- An inverter system with sinusoidal output shall be supplied capable of powering any combination of lighting fixtures, including incandescent, fluorescent, induction and/or LED light sources without compatibility problems.
- The system shall transfer in less than 1.0 second to reliably back up lighting fixtures without loss of illumination and operate any and all connected lighting fixtures at full lumen output during the complete 90 minute discharge cycle.
- The input voltage shall be the same as the output voltage and shall be single phase 120/277 volts, 60 Hz. Output capacity will be (20 Watts/32 Watts) | (35 Watts/55 Watts) for a minimum duration of 90 minutes.
- The design shall be a standby, off-line inverter with on-line efficiency of 98%; on-line double conversion UPS systems shall not be considered acceptable alternatives. EMS system output shall be a PWM generated sine wave with less than 3% total harmonic distortion. The system shall also provide short circuit and overload protection as standard.
- An intuitive three LED display shall provide system operational information at a glance and alert user to any malfunction in system performance. Authorized maintenance personnel shall have access to the system's controls while being protected from any live exposed connections.
- Protective devices shall include DC input fuse, AC input overcurrent protection for live circuits to be provided by service panel rated 20A maximum. AC lockout, reverse battery connection, low voltage battery disconnect (LVD), short circuit and overload protection shall be provided standard on all models. The entire EMS system, including batteries, shall be provided in compact cabinetry which shall have provisions or (surface)(recessed)(T-Grid) mounting.
- System shall utilize a (sealed lead calcium battery with a 10 year design life)(sealed Nickel-Cadmium battery with a 15 year design life). The charger shall be temperature compensated, dual mode type, and recharge the batteries as per UL 924 guidelines. Entire system shall be tested, approved, and labeled to UL924 Emergency Lighting and Power Systems standards. T-Grid models will be plenum rated.

AC INPUT CONNECTION

VOLTAGE SELECT DETAIL

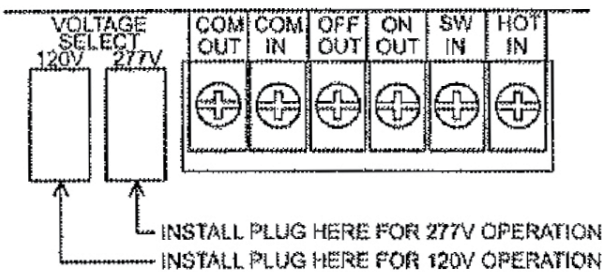

NOTE: Voltage selection plug is shipped loose from factory. User installation required.

STANDARD WIRING DIAGRAMS

A. NORMALLY ON LOADS

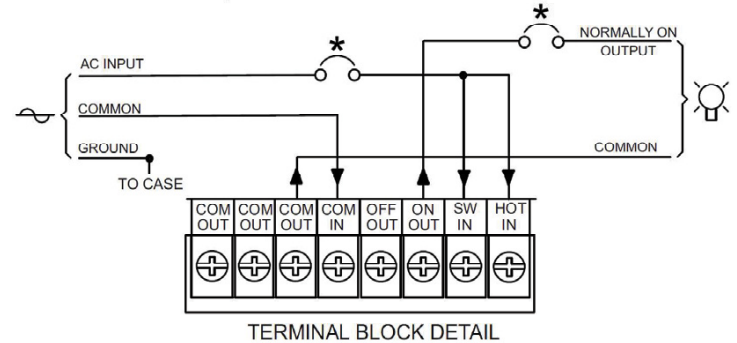

B. NORMALLY OFF LOADS

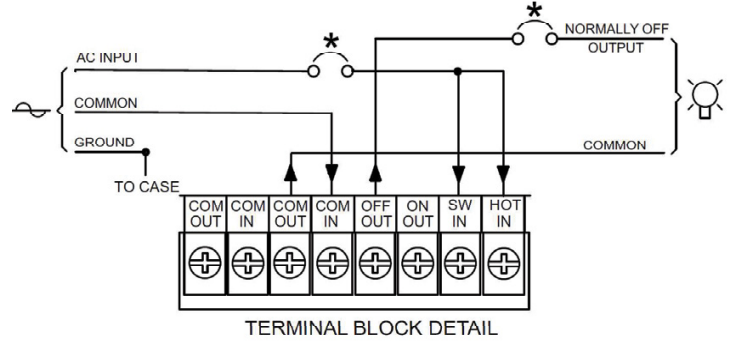

C. NORMALLY ON & OFF LOADS



Combined Normally On & Off Loads
 note to exceed load rating of system

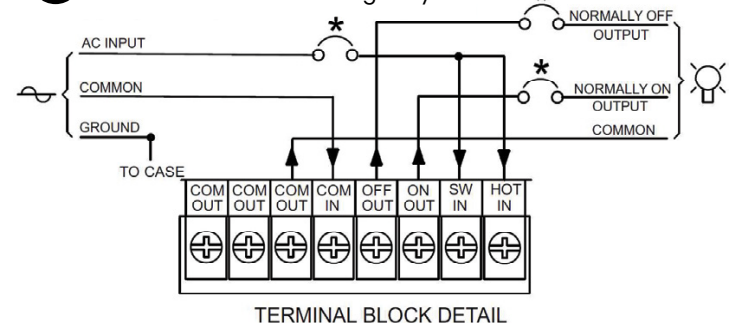

D. SWITCHED LOADS

