



EVENLITE
LIVES DEPEND ON US

RBH

INSTALLATION AND OPERATING INSTRUCTIONS

IMPORTANT SAFEGUARDS

When using electrical equipment, basic safety precautions should always be followed including the following:

READ AND FOLLOW ALL SAFETY INSTRUCTIONS

1. DO NOT use outdoors.
2. DO NOT mount near gas or electric heaters.
3. Equipment should be mounted in locations and at heights where it will not be readily subject to tampering by unauthorized personnel.
4. The use of accessory equipment is not recommended by the manufacturer. Use of such equipment may cause an unsafe condition.
5. DO NOT use this equipment for other than intended use.
6. Conduct periodic visibility tests in accordance with the applicable installation code (such as NFPA 101).
7. Supply connections MUST be made inside the junction box.
8. Install using recommended junction box ONLY.
9. Servicing of this equipment should be performed by a qualified service personnel.
10. Install sign indoors only where not exposed to direct unfiltered sunlight, liquid spray or temperatures outside of the range of 10°C to 40°C.
11. Before installing unit, disconnect power at breaker panel.

SAVE THESE INSTRUCTIONS

2575 Metropolitan Drive • Trevoze, PA • 19053 U.S.A
Telephone: (215) 244-4204 • Fax: (215) 244-4208

BACK MOUNT WITH ANCHORS

Install RZR3 EXIT sign as per document Z410139 - Back Mounted Installation Instructions

1. Place Anti-Ligature Cover over the RZR3 and Pre-drill 8x holes with a $\text{\O}1/8''$ drill bit.
 - a. If a Pre-drilled hole hits a stud, no Anchor is needed.
2. Use Twist-in anchors for any holes that are not backed by a stud.
 - a. Make sure the anchor is flush with the wall.
3. Place Cover over RZR3 and secure with supplied #8 Tamper Resistant screws.

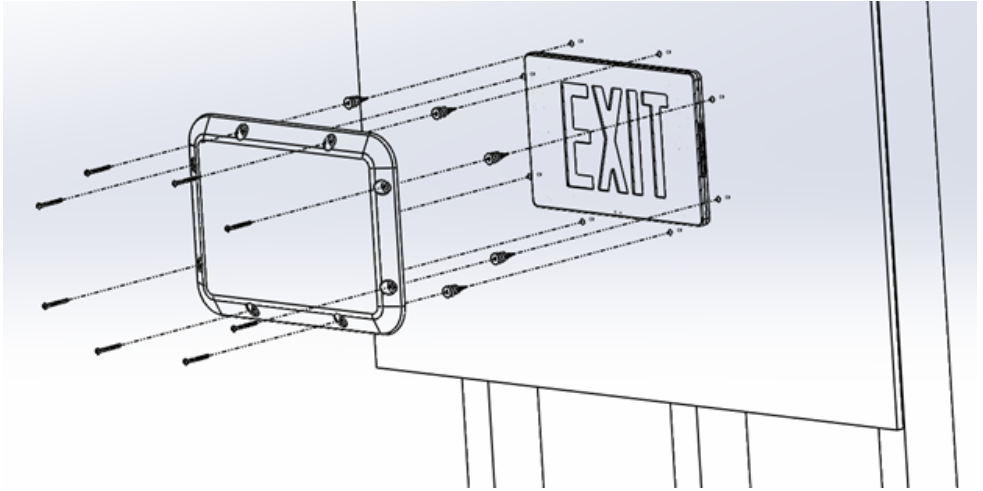

FIGURE 1: BACK MOUNT WITH ANCHORS

BACK MOUNT WITH FRAMED SUPPORT

1. See Figure #2 for the 8x screw locations.
2. See Figure #2 for example Framed layout.
3. Install RZR3 EXIT sign.
4. Place Anti-Ligature Cover over the RZR3 and Pre-drill 8x holes with $\text{Ø}1/8''$ drill bit.
5. Secure cover with supplied #8 Tamper Resistant screws.

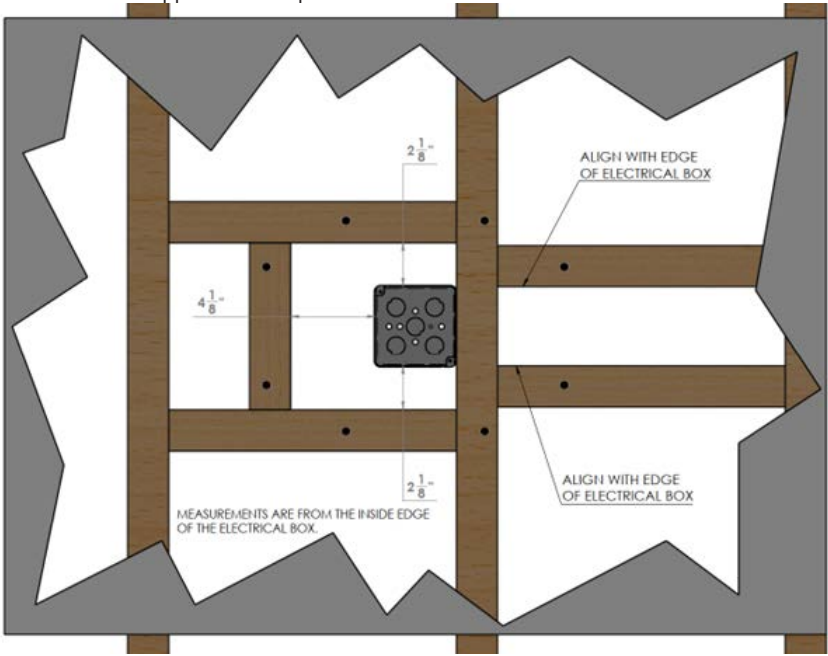

FIGURE 2: FRAMED SUPPORT

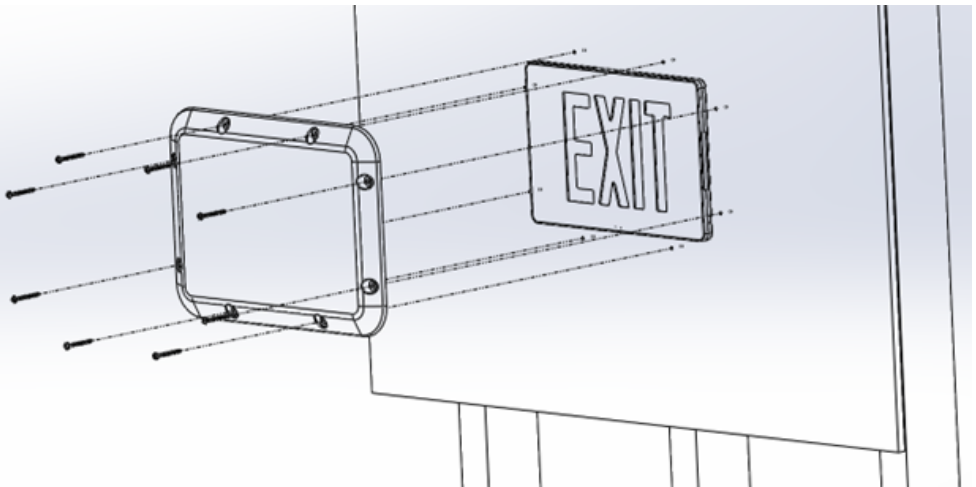

FIGURE 3: BACK MOUNT WITH FRAMED SUPPORT



EVENLITE

LIVES DEPEND ON US

SAVE THESE INSTRUCTIONS

2575 Metropolitan Drive • Trevose, PA • 19053 U.S.A

Telephone: (215) 244-4204 • Fax: (215) 244-4208