



EVENLITE

LIVES DEPEND ON US

SOVEREIGN II SERIES

Die Cast Aluminum LED Edge Lit Exit Sign

INSTALLATION AND OPERATING INSTRUCTION

Signs furnished with transparent backgrounds shall be installed only where there is adequate color contrast between the sign legend and the interior wall finish behind the sign, to provide for sufficient visibility.

IMPORTANT SAFEGUARDS

When using electrical equipment, basic safety precautions should always be followed including the following:

READ AND FOLLOW ALL SAFETY INSTRUCTIONS

1. Do not use outdoors.
2. Do not mount near gas or electric heaters.
3. Equipment should be mounted in locations and at heights where it will not readily be subject to tampering by unauthorized personnel.
4. The user of accessory equipment not recommended by the manufacturer may cause an unsafe condition.
5. Do not use this equipment for other than intended use.
6. Supply connections must be made either inside the junction box for surface mount or the splice box in the recessed mount backbox.
7. Install using recommended junction box only.
8. Servicing of this equipment should be performed by qualified service personnel.

SAVE THESE INSTRUCTIONS

2575 Metropolitan Drive • Treose, Pa • 19053 U.S.A
Telephone: (215) 244-4204 • Email: servicesupport@evenlite.com

FIELD INSTALLED DIRECTIONAL INDICATORS (CHEVRONS)

Directional indicators (chevrons) are supplied with the sign, if requested. The chevrons are affixed to the sign at the factory or supplied with an alignment template, chevrons (qty 2 or 4) and a tool for field installation.

Signs can be ordered in various configuration such as single or double face and with a background color (clear, white or mirrored). The appropriate chevron will be supplied based on the ordered configuration.

Prior to installation of the chevrons, make sure the sign is clean with no dust particles in the application area. To install the chevron(s) on a single face sign, temporarily adhere the alignment template's tacky surface to the back (prints) side of the legend panel [Figure 1] (chevrons used in this application will have a white backing). Remove the adhesive backing from the chevron(s) and adhere to the panel in the location determined by the template [Figure 2]. The white backing of the legend should correspond with the white backing of the chevron. Lay the tool provided on it's side and perpendicular to the chevron [Figure 4]. Apply even pressure and push any air bubbles to the edge of the chevron starting from the middle to the top. Repeat this process for the bottom half also.

For double face or white/mirrored background signs, use the alignment template [Figure 1] to determine the location of the chevron(s) [Figure 3]. Chevrons' used in this application will be the same color on the front and back (adhesive) side. Remove the adhesive backing and adhere to panel. Use the tool provided to remove any air bubbles [Figure 4].

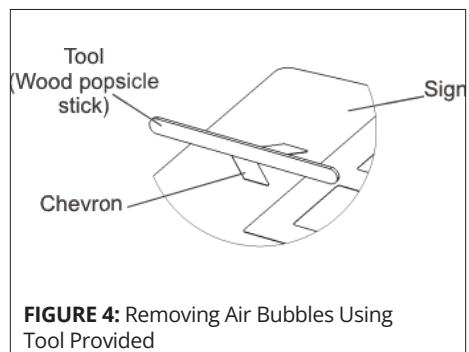
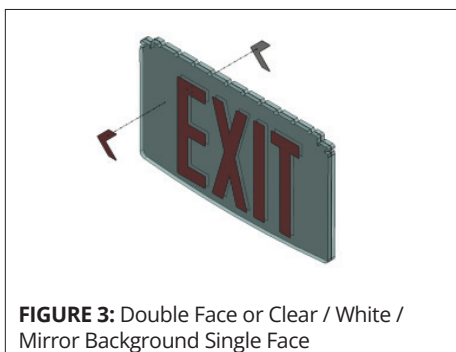
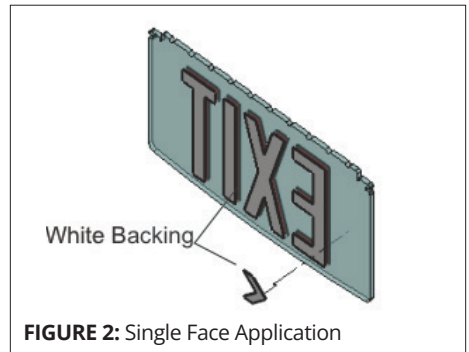
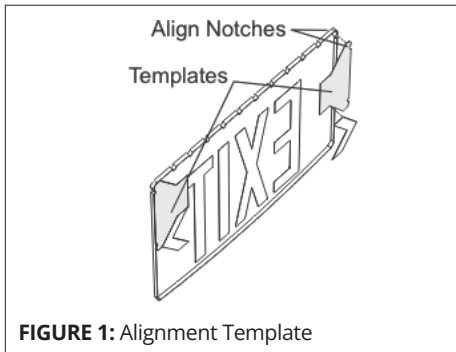

RECESSED CEILING MOUNT

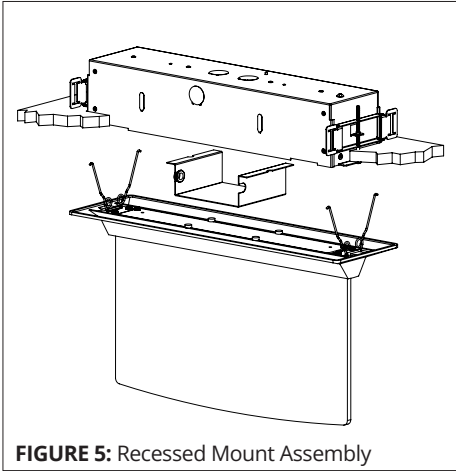

FIGURE 5: Recessed Mount Assembly

INSTALLATION OF ROUGH-IN SECTION

Hanger bars are adjustable from 13 1/4" to 22" and may be mounted on either the long sides or the ends of the back box. Remove splice box cover, select and remove desired knockout for AC power input. Refer to wiring instructions below.

Cut 3 5/8" x 14 1/2" hole in ceiling. Position back box with open edges flush with outer surface for ceiling

WOOD JOISTS - Adjust hanger bars to fit against joists. Drive nails into wood.

SUSPENDED CEILING - Snap ends of hanger bars over T-bar rails and fasten with screw.

BACKBOX ADJUSTMENT SCREWS

From below, using a Phillips head screwdriver, spin the backbox height adjustment screws to ensure that the backbox sits flush with the ceiling [Figure 7].

INSTALLATION OF FIXTURE INTO ROUGH-IN SECTION

Position fixture with desired orientation. Squeeze spring wires of one "wishbone" clip and insert into formed legs at one end of backbox. For battery backup signs, plug battery connector and transformer connector into plugs on printed circuit board. Attach power plug into power receptacle assemble wired as per wiring instruction below. Insert second "wishbone" clip into remaining formed legs in backbox and push fixture flush with ceiling.

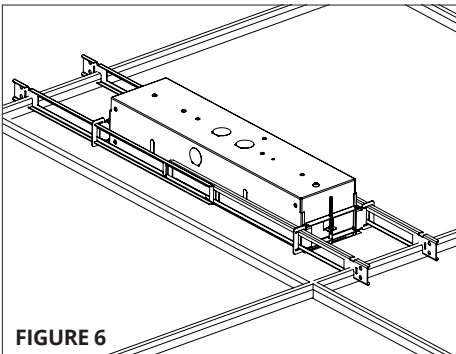

FIGURE 6

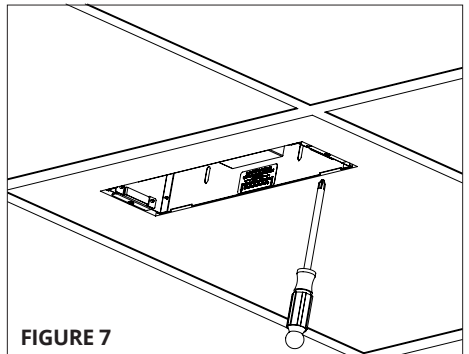

FIGURE 7

SURFACE MOUNT (END, CEILING, BACK)

END SURFACE MOUNT

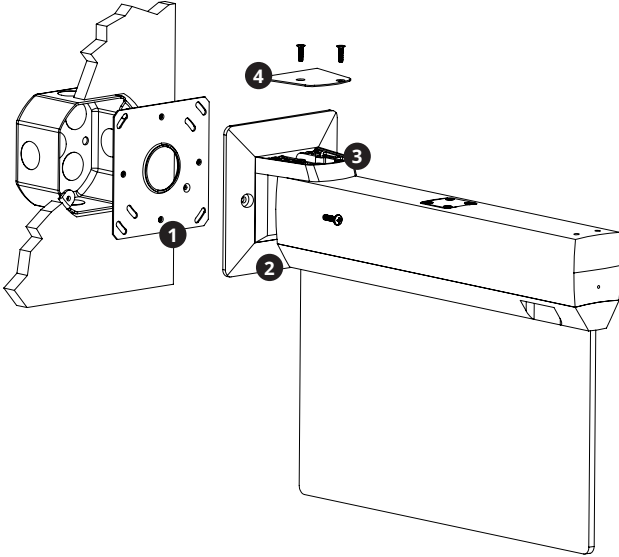

FIGURE 8: Surface End

CEILING SURFACE MOUNT

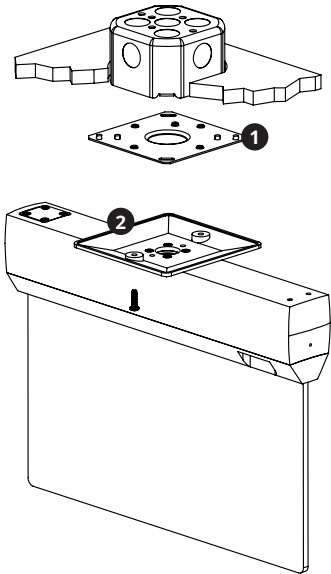

FIGURE 9: Surface Ceiling

BACK SURFACE MOUNT

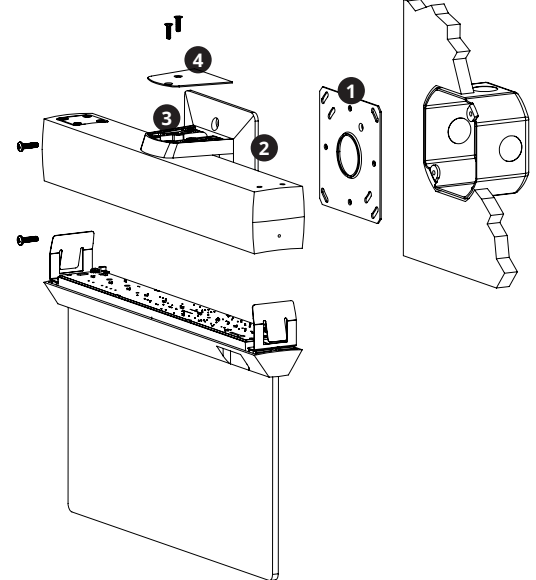

FIGURE 10: Surface Back

INSTALLATION OF JUNCTION BOX AND SPIDER PLATE

Surface mounting requires a 4" octagon junction box to be securely mounted in the wall, note that surface back and surface ceiling mounting may also be accomplished with a 4" square junction box. The box should be rigidly supported to the wall framework with either brackets or studs. Wire power receptacle assembly to the AC supply as per wiring instructions below. Securely fasten spider plate to junction box with the two #8-32 tapped holes.

REMOVE THE LENS HOLDER (SURFACE BACK ONLY)

In order to allow access to the bottom mounting screw on the canopy, it is necessary to remove the lens holder from the main assembly. Insert a 1/16" rod (or paperclip) into the hole in the side of the main housing to release the lens holder. Disconnect the battery terminal, then proceed with the installation. Once the canopy is mounted to the spider plate, reconnect the battery and snap the lens holder into position, **taking care to not pinch any wires or press the connector against any components.**

INSTALLATION OF FIXTURE TO SPIDER PLATE

Attach power plug to power receptacle and push back into fixture. Fasten fixture to spider plate with supplied countersunk screws.

ATTACH THE GOOSE-NECK COVER

Attach the goose-neck cover (surface end and surface back only) using the provided screws.

PRODUCT KEY

- 1 SPIDER PLATE
- 2 CANOPY
- 3 GOOSE-NECK
- 4 GOOSE-NECK COVER

HANG-STRAIGHT PENDANT MOUNT ASSEMBLY

FIGURE 11: Pendant Assembly

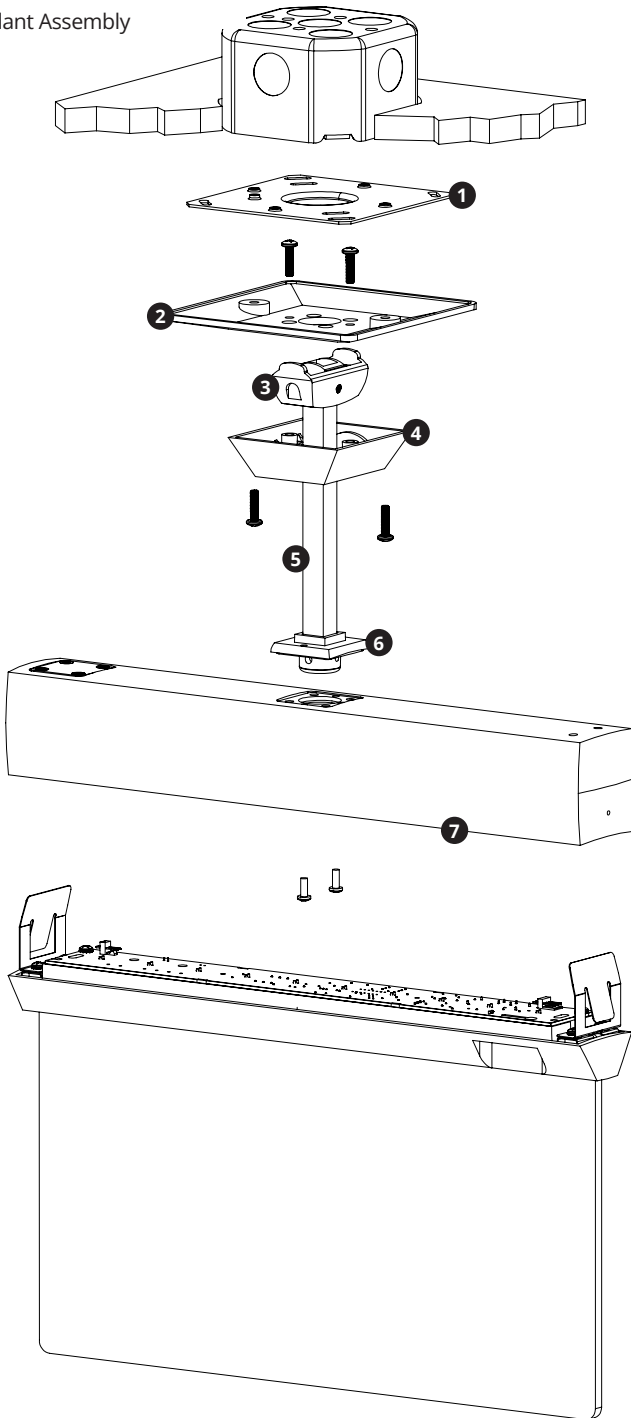

1. Insert pendant stem/universal joint assembly through the saddle.
2. Attach the housing to the pendant coupling with the provided screws, set aside the assembly.
3. Affix the spider plate to the 4" octagon junction box.
4. Attach the saddle (from the pendant assembly) to the canopy with the provided screws.
5. Connect wires according to local codes.
6. Attach canopy to the spider plate with the provided screws.

PRODUCT KEY

- 1** SPIDER PLATE
- 2** CANOPY
- 3** UNIVERSAL JOINT
- 4** SADDLE
- 5** PENDANT STEM
- 6** PENDANT COUPLING
- 7** HOUSING

MOUNTING BRACKET ASSEMBLY FOR MULLION INSTALLATION

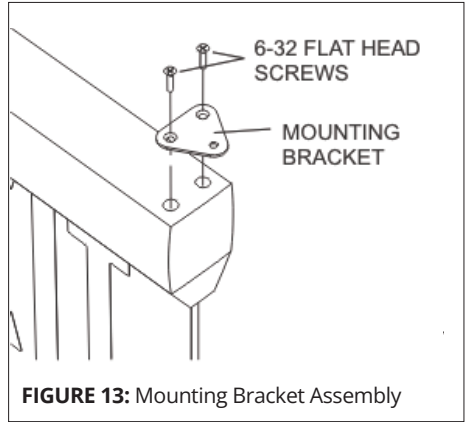
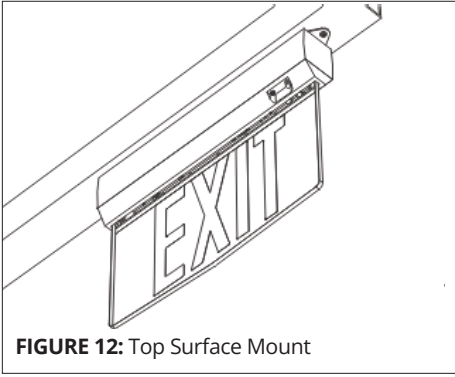

UNIVERSAL SURFACE INSTALLATION

SURFACE CEILING/SURFACE WALL

For surface ceiling and surface wall mount installation follow the standard surface mounting instructions found in this guide (see page 4-5).

SURFACE END

For surface end installation, please perform the following instructions:

1. Remove the lens holder by inserting a 1/16" rod (or paperclip) into the hole on the end of the housing.
2. Move the wire entry cover plate from the "end" [Figure 16] position to the "center" position [Figure 17].
3. Route the wire harness and quick connector around the transformer and out the "end" wire entry [Figure 18].
4. Connect and install the end mount assembly as per the instructions in this guide.
5. Replace the lens holder by snapping it into the housing.

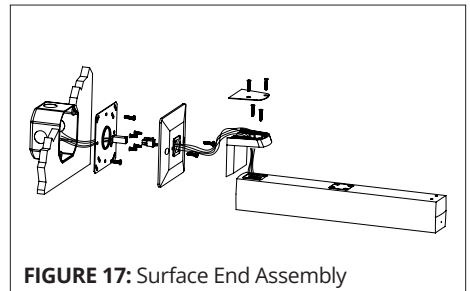
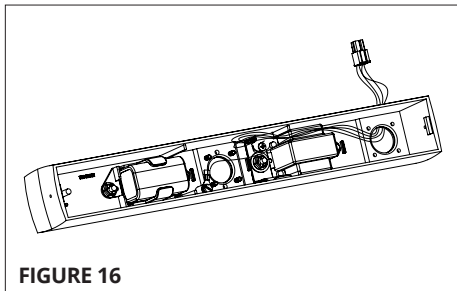
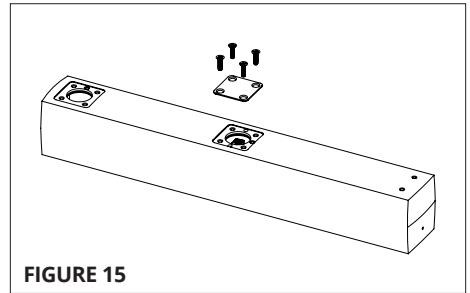
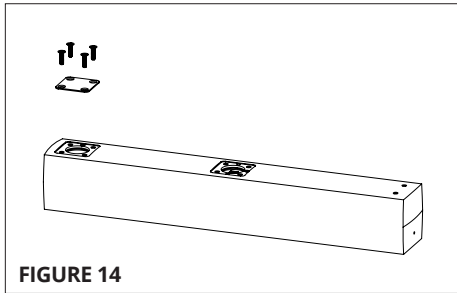

TWO CIRCUIT INPUT OPTION (AC VERSIONS ONLY)

For AC versions with two circuit input, connect power to the input wires as follows (refer to case 1 and case 2 diagrams below):

Case 1 (Backup power is Normally On): Connect main power to input 1 and backup power to input 2.

Case 2 (Backup power is Normally Off): Connect backup power to input 1 and main power to input 2.

CASE 1: Backup Power is Normally On

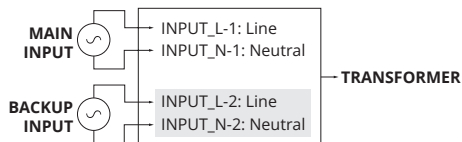

CASE 2: Backup Power is Normally Off

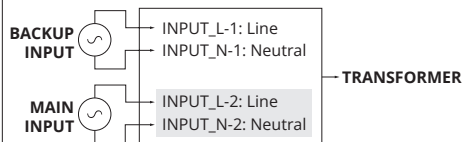

FLASHER, FIRE ALARM AND BUZZER OPTIONS

Battery backup signs equipped with “FLASH IN EMERGENCY MODE” or “BUZZER IN EMERGENCY MODE” options will automatically flash/beep in emergency mode but not flash/beep on AC operation. AC only signs equipped with the flasher or buzzer options will flash/beep continuously while power is supplied.

AC only and Battery Backup signs equipped with the FIRE ALARM SIGNAL FLASH or BUZZER options will automatically flash/beep in both AC and emergency modes upon application of a fire alarm signal to the YELLOW 18 AWG leads. The fire alarm signal can be either AC or DC of either polarity and range from 12 to 24 volts. The current draw from the fire alarm signal is less than 10 milliamps.

Units that include one of the above options are intended in locations where such features are permitted by local codes. Flash rate 60/min, duty cycle: 50%

TEST FOR BATTERY BACKUP WITHOUT SELF-TEST FEATURE

The test (EM) battery backup units, use the test switch to simulate AC power outage. The indicator light will go out and the sign will remain lit, indicating transfer to emergency mode; and remain lit on battery power until switch is released. Release of switch will automatically restore AC/battery charge mode, with indicator light on. Testing for longer periods is best accomplished by turning off AC circuit power. Signs should be tested in accordance with National Electrical Code and NFPA 101 Life Safety Code requirements, which specify monthly testing for 30 seconds and yearly testing for 90 minutes. Note that the batteries will take some time to reach full charge after a prolonged test, and that the unit cannot provide full duration operation should a real power outage occur before the batteries have had an opportunity to reach full charge. It is recommended that long duration tests be limited to once yearly and be conducted when the area will be unoccupied afterwards.

SELF-TESTING OPERATING INSTRUCTIONS

This unit meets requirements of NFPA 101 for period testing of emergency lighting equipment. It provides visual indication of unit malfunctions including “Battery Fault”, “Charger Fault”, “Transfer Fault” and “Lamp Fault”.

SELF-TEST

The unit will perform a self-test and diagnostic function at least once every 28 days. The self-test will disable the charger and turn on the LEDs for 5 minutes to check the lamp load and battery. The test will be performed only if the battery is fully charged. If not, the test will automatically reschedule. Charger function is monitored continuously.

USER-TEST

A user-test may be performed at any time the status display is continuously green. On initial power-up, it could take up to 72 hours for the status display to reach continuous green.

With a fully charged battery, pressing the test switch momentarily will initiate a 30 second test. Holding the test switch for 4 seconds will initiate a 90 minute test.

Either test can be canceled by pressing the test switch again for 1 second.

REMOTE EXIT OPERATION

The self-diagnostic system “learns” the exit load when the unit reaches full charge for the first time. It is therefore necessary to have any remote exits already connected when first applying AC power. Subsequent self-tests and user-tests will compare the actual exit load to the “learned value”.

If the remote exit load is changed once it has been learned, it is necessary to disconnect AC power at the circuit breaker panel and unplug the internal battery. Once these are reconnected, the unit will “learn” the new exit load.

INFRARED REMOTE TESTING

To activate TRANSMITTER, remove tab from the back of the device.

The USER-TEST can be performed up to 20 feet away using the optional “INFRARED REMOTE TESTING TRANSMITTER”. By aiming the transmitter at the legend face and pushing either the “30 SECOND” or “90 MINUTE” button for 1 second. The behavior of the exit sign is the same as when the user tests are initiated from the local test button.

STATUS INDICATORS

STATUS DISPLAY	MEANING	ACTION
Continuous Green	Battery in Float / Trickle Charge	None
Continuous Red	Battery High Charging	Wait for Green Status
Flashing Green	In Test Mode	Wait for Test to Complete
Alternate Red & Green	Insufficient Charge for User Test	Wait for Full Charge
Red Single Blink (ON / Pause)	Transfer System Failure	Factory Service
Red Two Blinks (ON / Pause)	Battery Failure	Check Connections / Replace Battery
Red Three Blinks (ON / Pause)	Charger Failure	Factory Service
Red Four Blinks (ON / Pause)	Lamp Failure	Check Remote Connection / Factory Service

BATTERY REPLACEMENT

To replace battery, disconnect branch circuit and detach unit from junction box. Unplug battery connector from printed circuit assembly. Replace battery only with part number B310023.

This product contains NiCd batteries. Used NiCd batteries may not be disposed of in the municipal solid waste stream. NiCd batteries must be recycled or disposed of properly. For information on local recycling drop-off points, phone toll free 1-800-BATTERY (1-800-228-8379).

OLD WORK CLIPS

1. Remove Hanger-Bars & Screws: Carefully take out the hanger-bar assemblies and remove the screws from both ends of the back-box. [FIGURE 18]
2. Attach Old Work Clips: Locate the 4 notches on the back-box. Attach the provided old work clips to these notches. [FIGURE 19]
3. Install and Secure Back Box: Insert the back-box into the ceiling opening. Tighten the old work clips to secure the back-box in place.

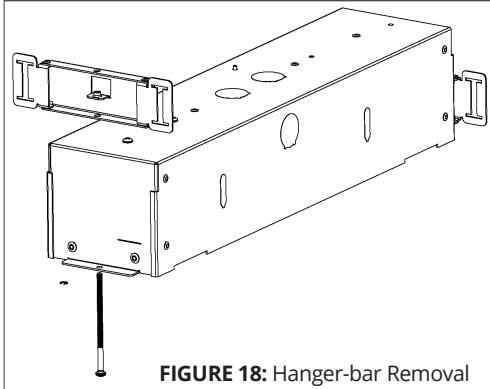

FIGURE 18: Hanger-bar Removal

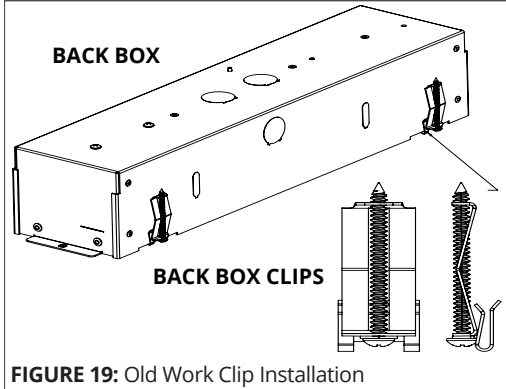

FIGURE 19: Old Work Clip Installation

OLD TO NEW PANEL REPLACEMENT FOR SOV

From	SOV 1C	SOV 1M	SOV 1W	SOV 2M	SOV 2W	SOVII 1C	SOVII 1M	SOVII 1W	SOVII 2M	SOVII 2W
SOV 1M		NO	NO	NO	NO	YES	YES	YES	YES	YES
SOV 1C	NO		YES	YES	YES	NO	NO	NO	NO	NO
SOV 1W	NO	YES		YES	YES	NO	NO	NO	NO	NO
SOV 2M	NO	YES	YES		YES	NO	NO	NO	NO	NO
SOV 2W	NO	YES	YES	YES		NO	NO	NO	NO	NO
SOVII 1C	YES	NO	NO	NO	NO		YES	YES	YES	YES
SOVII 1M	YES	NO	NO	NO	NO	YES		YES	YES	YES
SOVII 1W	YES	NO	NO	NO	NO	YES	YES		YES	YES
SOVII 2M	YES	NO	NO	NO	NO	YES	YES	YES		YES
SOVII 2W	YES	NO	NO	NO	NO	YES	YES	YES	YES	

SOVII MOUNTING REQUIREMENTS

FROM	SURFACE BACK/WALL	SURFACE TOP/CEILING	SURFACE END/FLAG
SURFACE BACK/WALL		YES	YES
SURFACE TOP/CEILING	NO		NO
SURFACE END/FLAG	YES	YES	

NOTES
Remove gooseneck from canopy to ceiling mount
Requires gooseneck kit
Remove gooseneck from canopy to ceiling mount