

# EMS750

## 750VA Single Phase Inverter

The EMS Series is designed to provide 750 watts of emergency power to Incandescent, Fluorescent, Induction and/or LED fixtures. The EMS unit provides clean, sinusoidal AC output power allowing it to be remotely mounted up to 1,000 feet away from the controlled fixture(s).

Unlike a ballast fluorescent emergency pack, the EMS750 provides power to the input side of the fixture (including the fixture ballast) eliminating any chance of incompatibility. The EMS Series is designed for surface mounting. All EMS systems will provide emergency power output for a minimum of 90 minutes.



### FEATURES

- Input circuit breaker included as standard
- For powering incandescent, fluorescent, induction and LED fixtures
- Sinusoidal output eliminates compatibility problems
- Universal 120/277VAC, 60Hz input/output
- "Soft Start" design reduces fixture inrush current
- Unit may be installed up to 1,000 feet from controlled fixture(s)
- Lumen output from fixture is 100% of nominal
- Unique design eliminates compatibility problems with LED drivers as well as fluorescent and induction ballasts
- Compatible with dimming ballasts
- Normally-ON and/or Normally-OFF load output
- Provisions for local switching capability - Always on during emergency conditions regardless of local switch position
- Emergency fixtures can be ON, OFF or SWITCHED
- Solid-state, line latched low voltage disconnect provides protection against battery deep discharge
- Long life, maintenance-free lead-calcium battery
- Momentary test switch
- AC-ON, Charge-ON and Inverter-ON LED indicators

### DESCRIPTION

- Midsize-electrical inverter system for powering up to 750 watts of incandescent, fluorescent, induction or LED lighting loads. Pulse width modulated (PWM) output design provides clean, 60 Hz sinusoidal emergency power to loads
- All models are designed for fast, easy wall mounting

### INPUT

- Input Voltages: Dual 120 or 277VAC  $\pm 10\%$  (User selectable with two jumper wires provided)
- Input Frequencies: 60Hz  $\pm 2\%$
- Input Surge Protection: Meets UL924
- Input Protection: Provided by Service Panel rated at 20 amps maximum
- Input Breaker

### OUTPUT

- Output Voltages: 120 or 277VAC, 60Hz
- Efficiency Rating: 98% at full rated load (line)
- Waveform: Sinusoidal (digitally controlled)
- Static Voltage:  $\pm 5\%$  during battery discharge. 0-100% linear load
- Output Frequencies: 60Hz  $\pm 0.3\text{Hz}$  during emergency cycle
- Output Distortion: Less than 3% THO (linear load)
- Transfer Time: 1-2 seconds
- Load Power Factor Range: 0.88 Lead to 0.88 Lag
- Minimum Loading: 0% of rated system capacity
- Output Protection: Circuit breaker and overload shut down protection

### WIRING

- Connection to an unswitched AC circuit is required by the NEC. Wiring access is provided for by conduit knockouts in the unit housing.

## LOAD COMPATIBILITY

- EMS model's clean, sinusoidal AC output will operate incandescent lamps as well as all common fluorescent, induction and LED lamp types. Consult factory for compatibility with all other lamp types. Lighting loads are driven at 100% output for the entire emergency power cycle. This outstanding feature translates into greater occupant egress vision and safety.

## HOUSING

- Heavy duty steel cabinet is finished in white baked-on powder paint providing scratch and corrosion resistance

## MOUNTING

- Surface mount models are designed for mounting to walls by means of keyhole slots provided in the back of the unit housing

## WARRANTY / LISTING

- Unit: Full coverage against defects in materials and workmanship for 3 years from date of shipment
- Battery: 3 years full warranty plus an additional 7 years of pro-rata coverage
- View complete warranty terms online at [www.evenlite.com/terms-warranty](http://www.evenlite.com/terms-warranty).
- All models are UL924 Listed and meet NFPA 101 Life Safety Code, NEC, OSHA, Local and State Codes.
- UL Listed for damp locations (20° to 30 °C)
- Certified to CEC Under Title 20 regulations
- FCC Part 15 Class A Compliant

## ORDERING GUIDE

EMS750-C4-SD

MODEL	VA RATING	OPTIONS	ORDERING NOTES
EMS	750 750 Watts/VA	<b>C(n)</b> 1-5 Output Circuit Breakers <sup>1</sup> <b>SD</b> Self-Test/Self-Diagnostics <b>S4</b> 4x Switched Circuits <sup>2</sup> <b>FD</b> 0-10V Dimming Option <sup>2</sup>	1 Total number of Circuit breakers not to exceed five 2 Options [S4] and [FD] are not available together
EMS	750		

Fill in fields from categories above and complete type and part number.

Type No: \_\_\_\_\_ Full Part No: \_\_\_\_\_

## SYSTEM SPECIFICATIONS

MODEL	INPUT/OUTPUT	CAPACITY FOR 1.5 HRS (WATTS/VA)	SYSTEM WEIGHT		SYSTEM EFFICIENCY (FULL LOAD)	NUMBER OF BATTERIES	NUMBER OF BATTERY STRINGS	BATTERY VOLTAGE (VDC)	BATTERY CURRENT (ADC)	AC INPUT CURRENT (MAX AMPS)		THERMAL OUTPUT (BTUs)	
			LBS	KG						120 VAC	277 VAC	ON-LINE	EMERGENCY
EMS750	120/277 VAC	750/750	190	86.2	98%	8	2	48	18.2	7.53	3.26	14	416

## DIMENSIONS

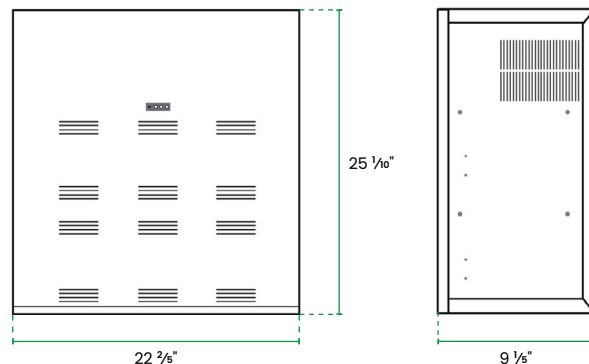

## **BATTERY**

- Battery: Sealed Lead Calcium (10 year life)
- Battery Voltage: 48VDC
- Runtime: 90-minutes standard - based on battery performance at (25°C)
- Battery Protection: Low Voltage Battery Disconnect protects the battery from being severely damaged by deep discharge during prolonged power failures. Reverse polarity, DC Overload and Short Circuit Protection provided by a DC input breaker and fuse.

## **CHARGER**

- Charger Type: Fully automatic, temperature compensated, dual-mode charger
- Power Consumption (Charger Only): 53W maximum (4.3W in standby)
- Recharge Duty Cycle: Meets UL924 requirements
- Battery Circuit Breaker: Also used as battery isolator
- Controls: Momentary test switch, AC-ON, Charge-ON and Inverter-ON LED indicator lights
- Safety Circuitry: AC Lockout prevents battery discharge prior to initial unit power-up
- Brownout Protection automatically switches the unit to emergency mode when utility voltage is significantly reduced

## **OPERATION**

- Upon failure of the normal utility power the EMS unit is automatically turned on by a solid state switching circuit and provides a minimum of 90 minutes of emergency power to the connected load. Lumen output will be maintained at 100% of the lamp's rating throughout the entire duration.
- When normal utility power is restored, the unit switches the load back to normal utility operation and the fully automatic, temperature compensated, dual mode charger begins to restore the battery; bringing it to full charge within UL 924 specified parameters.
- Improved Aesthetics
- The EMS system's sinusoidal AC output design eliminates voltage drop and proximity concerns. This allows added flexibility in installation location as EMS units can be installed hundreds of feet from the units they power. This means EMS units to be located conveniently out of sight in closets or utility rooms without interrupting architectural aesthetics.
- In lighting applications, no special or additional emergency fixtures are necessary. Simply designate and connect existing lighting fixtures, either interior or exterior, to the EMS unit for emergency operation eliminating the need for exposed, stand-alone emergency luminaires.

## **ENVIRONMENTAL**

- Altitude: < 10,000 feet (3,000m) above sea level without derating
- Operating Temperature Range: 20°C to 30°C
- Relative Humidity: 95% non-condensing
- NOTE: Optimum system performance between 20°C and 30°C; temperatures outside of this range will affect battery performance and life.

## **EMS SYSTEM ADVANTAGES**



- Compared to traditional discrete emergency lighting units, the EMS Series provides emergency illumination from a single power source resulting in lower maintenance overhead and routine testing expenses. EMS units lower installation costs by powering existing lighting fixtures during emergencies. And because connected fixtures are driven at full brilliancy, they provide far superior egress lighting and deliver improved occupant safety.

## **SUGGESTED SPECIFICATIONS**

- An inverter system with sinusoidal output shall be supplied capable of powering any combination of lighting fixtures, including incandescent, fluorescent, induction and/or LED light sources without compatibility problems.
- The system shall transfer in less than 1.0 second to reliably back up lighting fixtures without loss of illumination and operate any and all connected lighting fixtures at full lumen output during the complete 90-minute discharge cycle.
- The input voltage shall be the same as the output voltage and shall be single phase 120/277 volts, 60 Hz. Output capacity will be (750W/750VA) for a minimum duration of 90 minutes.
- The design shall be a standby, off-line inverter with on-line efficiency of 98%. EMS System output shall be a PWM generated sine wave with less than 3% total harmonic distortion with Soft Start design reducing fixture inrush current. The system shall also provide short circuit and overload protection as standard.
- An intuitive three LED display shall provide system operational information at a glance and alert user to any malfunction in system performance. Authorized maintenance personnel shall have access to the system's controls while being protected from any live exposed connections.
- Protective devices shall include AC Line fuses, DC input breaker and a DC input fuse. The entire EMS system, including batteries, shall be incorporated into compact cabinetry which shall have provisions for surface mounting.
- System shall be capable of providing up to 4 switch bypass circuits, adjustable output with 2.5 to 10 volt dimmer bypass and self-test/self-diagnostics, were necessary.
- System shall utilize a sealed lead calcium battery with a 10 year design life. The charger shall be temperature compensated, dual mode type, and recharge the batteries as per UL924 guidelines. Entire system shall be tested, approved, and labeled to UL924 Emergency Lighting and Power Systems standards.

**STANDARD WIRING DIAGRAMS**

**NOTES:**

-  Input supply from unswitched utility rated 20 amps maximum
-  Output(s) to lighting loads
- \* Available within unit as option

**A. NORMALLY ON LOADS**

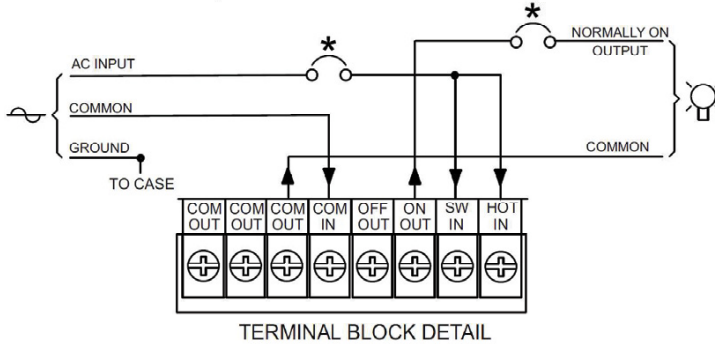

**B. NORMALLY OFF LOADS**

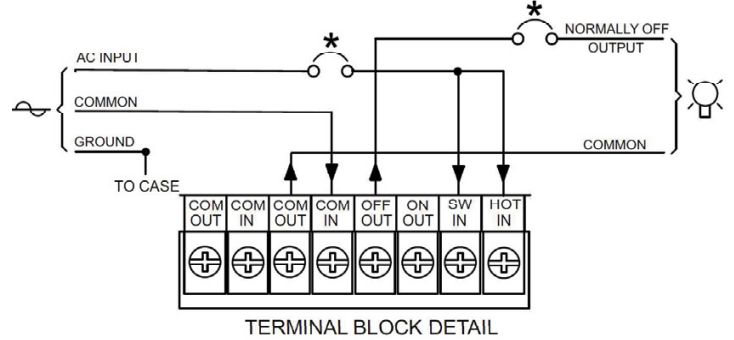

**C. NORMALLY ON & OFF LOADS**



Combined Normally On & Off Loads note to exceed load rating of system

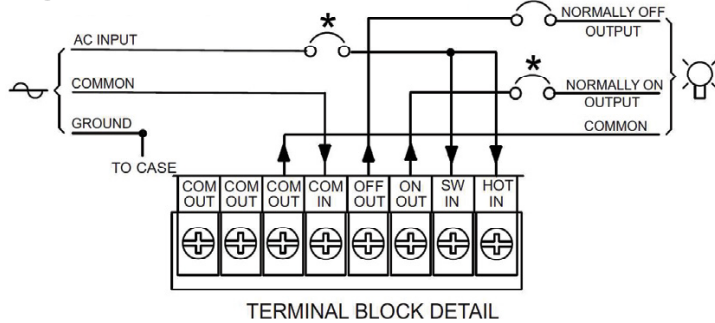

**D. SWITCHED LOADS**

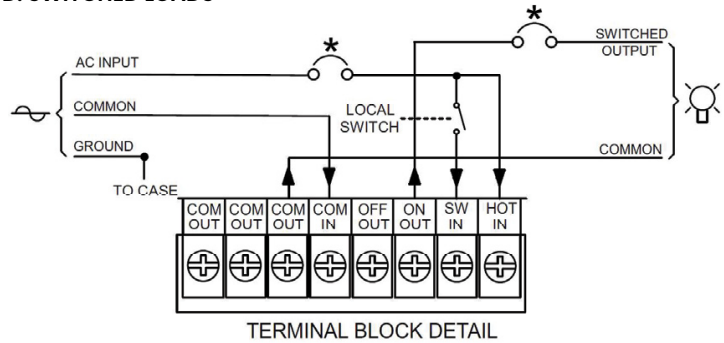

**VOLTAGE SELECTION DETAIL**

**NOTE:**

Factory terminated jumper wires are provided with EMS Systems for making user selected input/output voltage connections.

**120V INPUT**

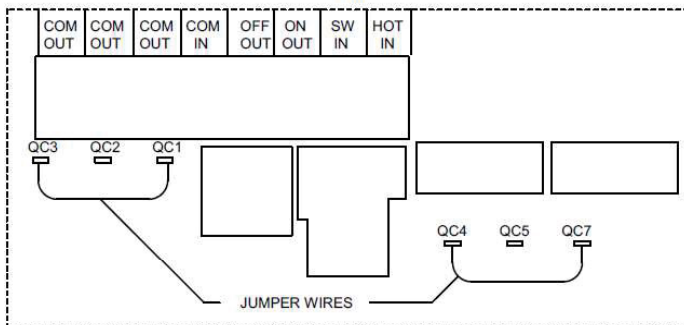

**277V INPUT**

